



Dr. SNS RAJALAKSHMI COLLEGE OF ARTS AND SCIENCE (AUTONOMOUS)

Accredited by NAAC (Cycle- III) with 'A+' Grade



DEPARTMENT OF B.SC CS (AI&DS)

21UCU407 – COMPUTER NETWORKS AND DATA COMMUNICATIONS
UNIT- I

Dr.SNSRCAS B.Sc CS(AI&DS)

Introduction

- Open Systems Interconnection Basic Reference Model (OSI Reference Model or **OSI Model**) is an abstract description for layered communications and computer network protocol design. It was developed as part of the **Open Systems Interconnection (OSI)** initiative. In its most basic form, it divides network architecture into seven layers which, from top to bottom, are the Application, Presentation, Session, Transport, Network, Data-Link, and Physical Layers. It is therefore often referred to as the **OSI Seven Layer Model**.

OSI Model's 7 Layers

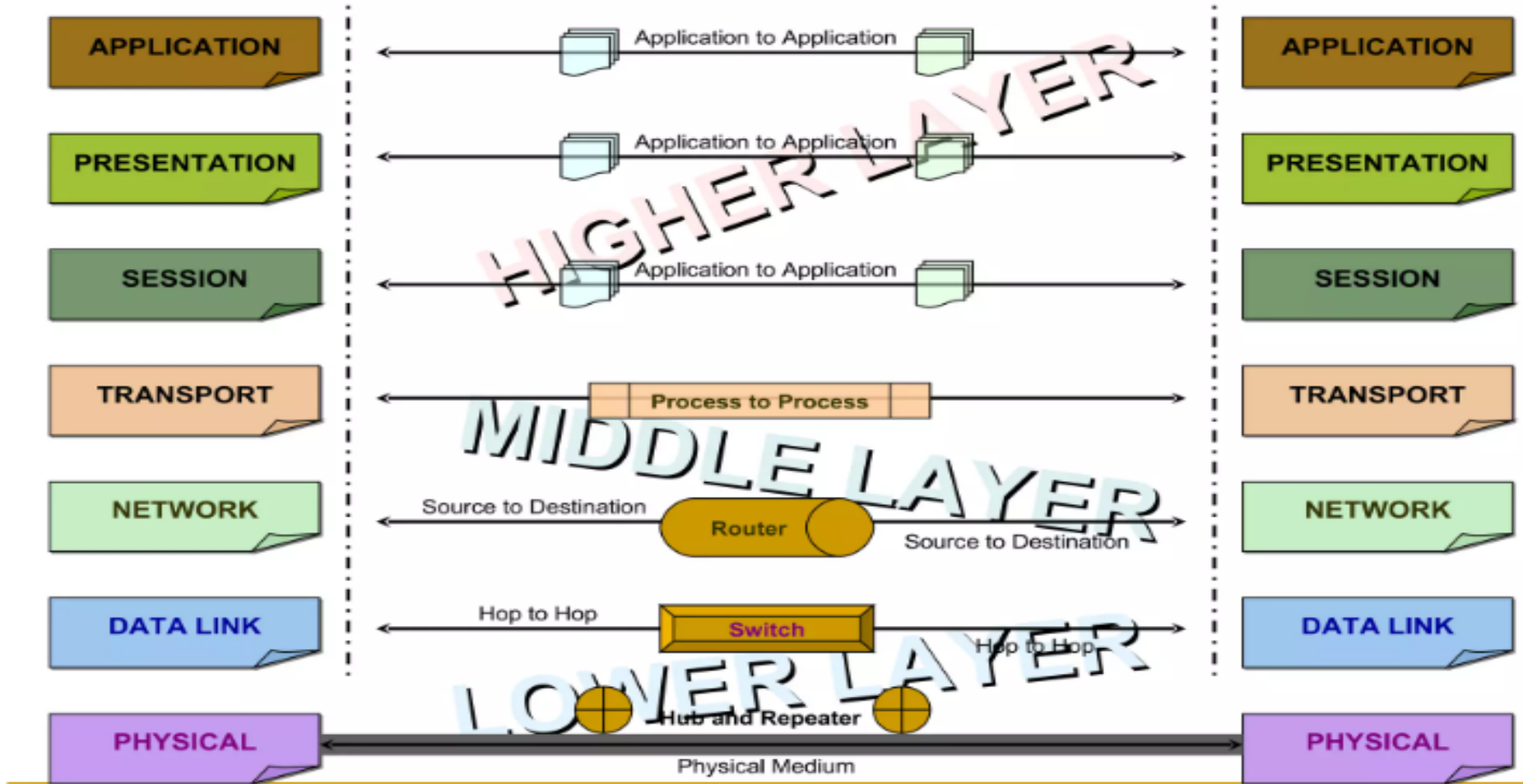

Host and Media Layer

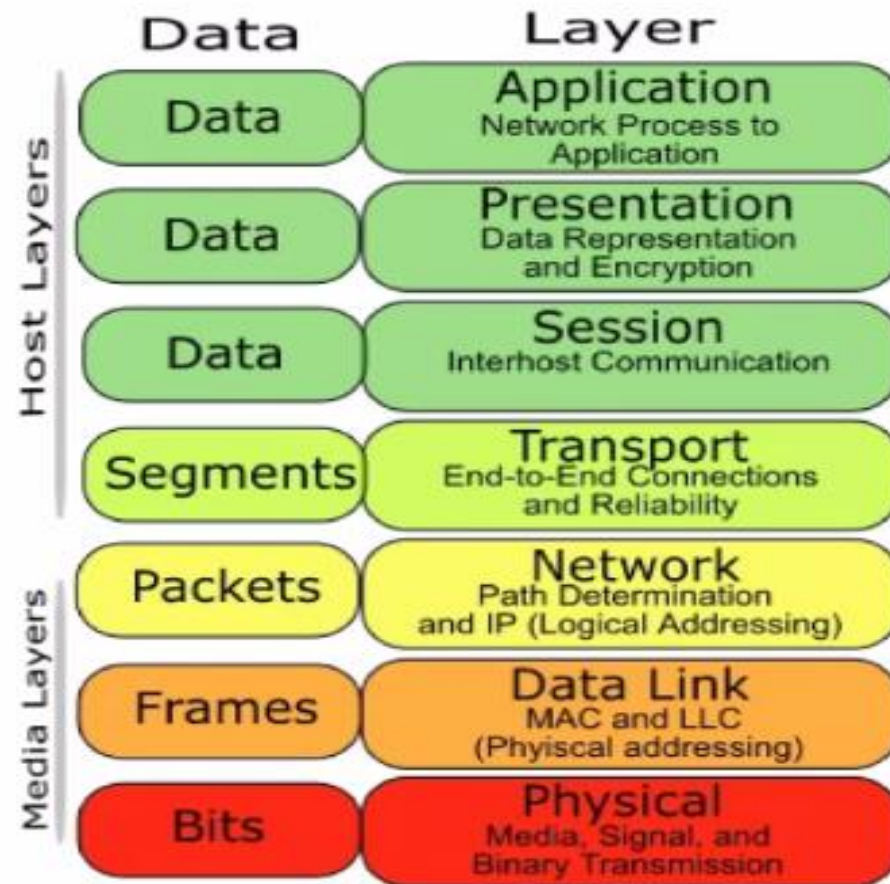

Data, Protocol & Activities

OSI Layers	TCP/IP Suit	Activities
Application	Application Telnet, FTP, SMTP, HTTP, DNS, SNMP, <i>Specific address etc...</i>	To allow access to network resources
Presentation	Presentation	To Translate, encrypt, and compress data
Session	Session	To establish, manage, and terminate session
Transport	Transport SCTP, TCP, UDP, Sockets and <i>Ports address</i>	To Provide reliable process-to-process Message delivery and error recovery
Network	Network IP, ARP/RARP, ICMP, IGMP, <i>Logical address</i>	To move packets from source to destination; to provide internetworking
Data Link	Data Link IEEE 802 Standards, TR, FDDI, PPP, <i>Physical address</i>	To organize bits into frames; to provide Hop-to-hop delivery
Physical	Physical Medium, Coax, Fiber, 10base, Wireless	To Transmit bits over a medium; to provide Mechanical and electrical specifications

Physical Layer

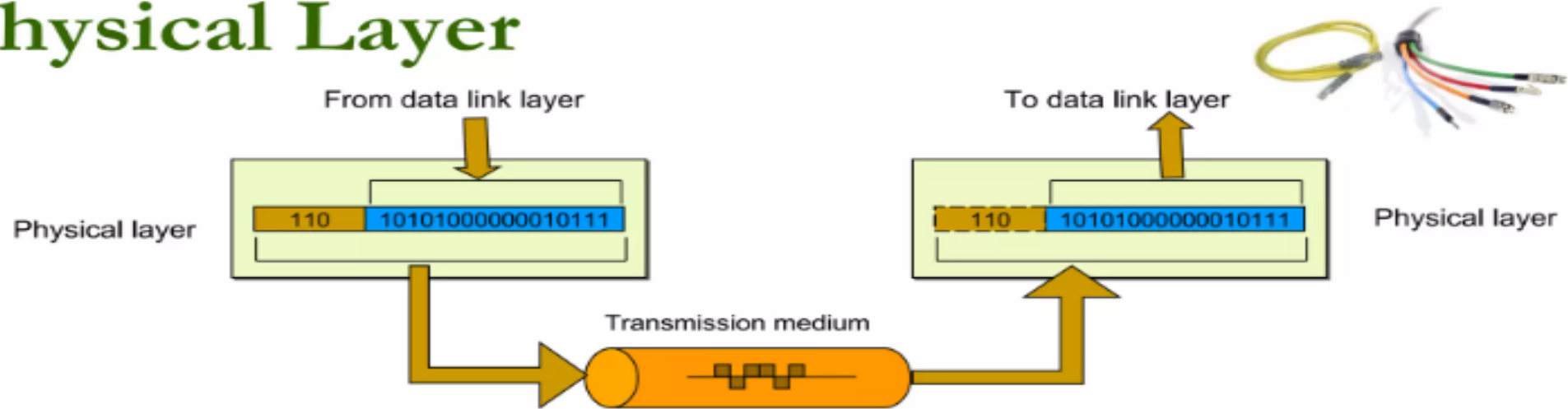

- One of the major function of the physical layer is to move data in the form of electromagnetic signals across a transmission medium.
- Its responsible for movements of individual bits from one hop (Node) to next.
- Both data and the signals can be either *analog* or *digital*.
- Transmission media work by conducting energy along a physical path which can be wired or wireless
- Concerned:
 - Physical characteristics of interface and medium (Transmission medium)
 - Representation of bits (stream of bits (0s or 1s) with no interpretation and encoded into signals)
 - Data rate (duration of a bit, which is how long it last)
 - Synchronization of bits (sender and receivers clock must be synchronized)
 - Line configuration (Point-to-Point, Point-to-Multipoint)
 - Physical topology
 - Transmission mode (Simplex, half duplex, full duplex)

Data Link Layer (Host to Host)

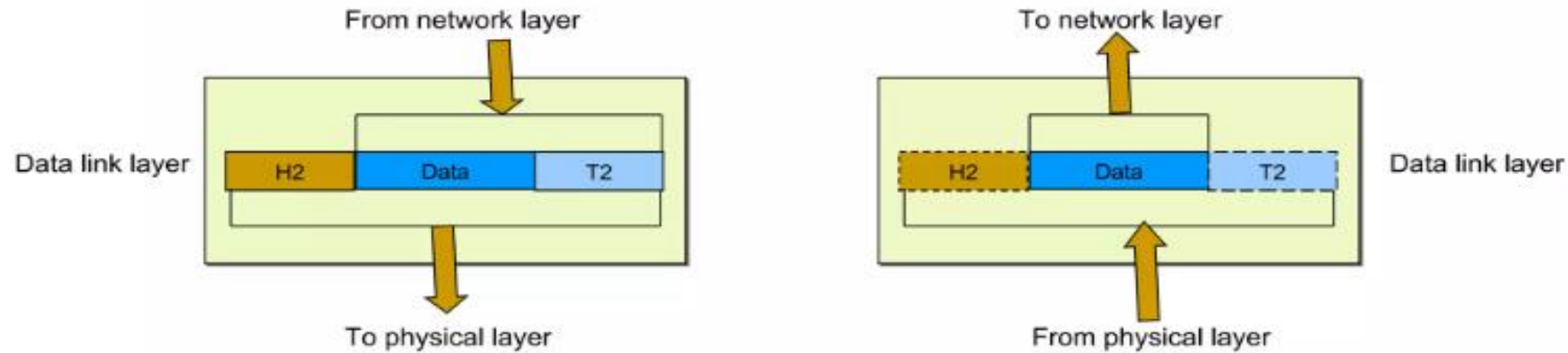

- Data link layer is responsible for moving frames from one hop (Node) to the next.
- Concerned:
 - Framing (stream of bits into manageable data units)
 - Physical addressing (MAC Address)
 - Flow Control (mechanism for overwhelming the receiver)
 - Error Control (trailer, retransmission)
 - Access Control (defining master device in the same link)

Network Layer (Source to Destination)

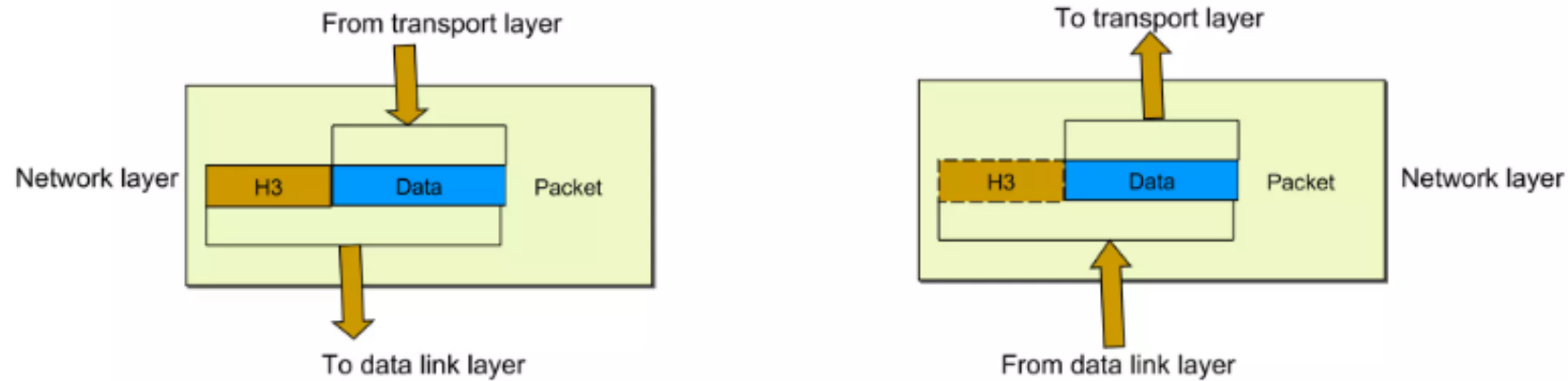

- The network layer is responsible for the delivery of individual packets from the source host to the destination host.
- Concerned:
 - Logical addressing (IP Address)
 - Routing (Source to destination transmission between networks)

Transport Layer (Process to Process)

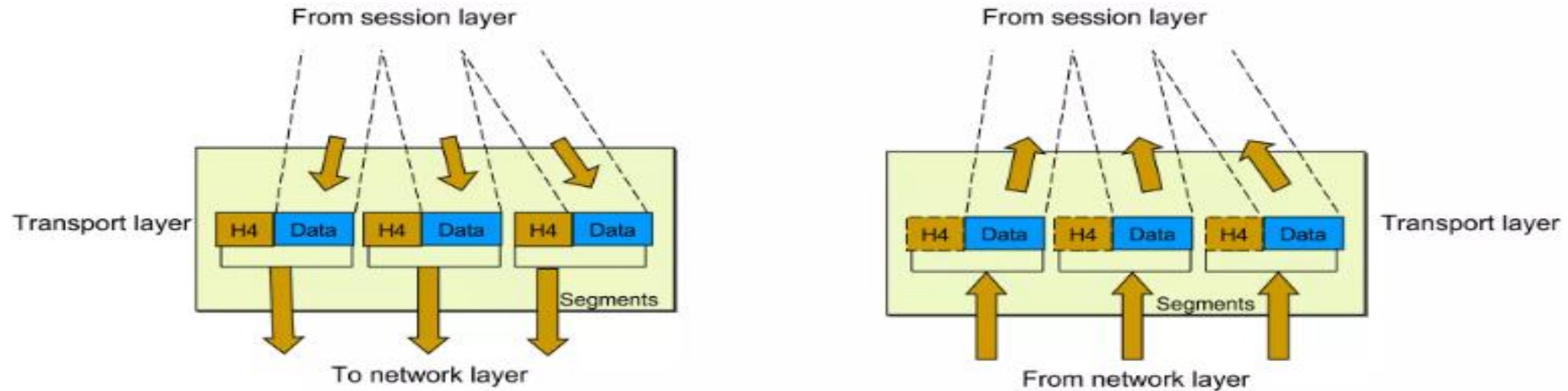

- The transport layer is responsible for the delivery of a message from one process to another
- Concerned:
 - Service-point addressing (Port address)
 - Segmentation and reassembly (Sequence number)
 - Connection control (Connectionless or connection oriented)
 - Flow control (end to end)
 - Error Control (Process to Process)

Session Layer (Dialog initiation)

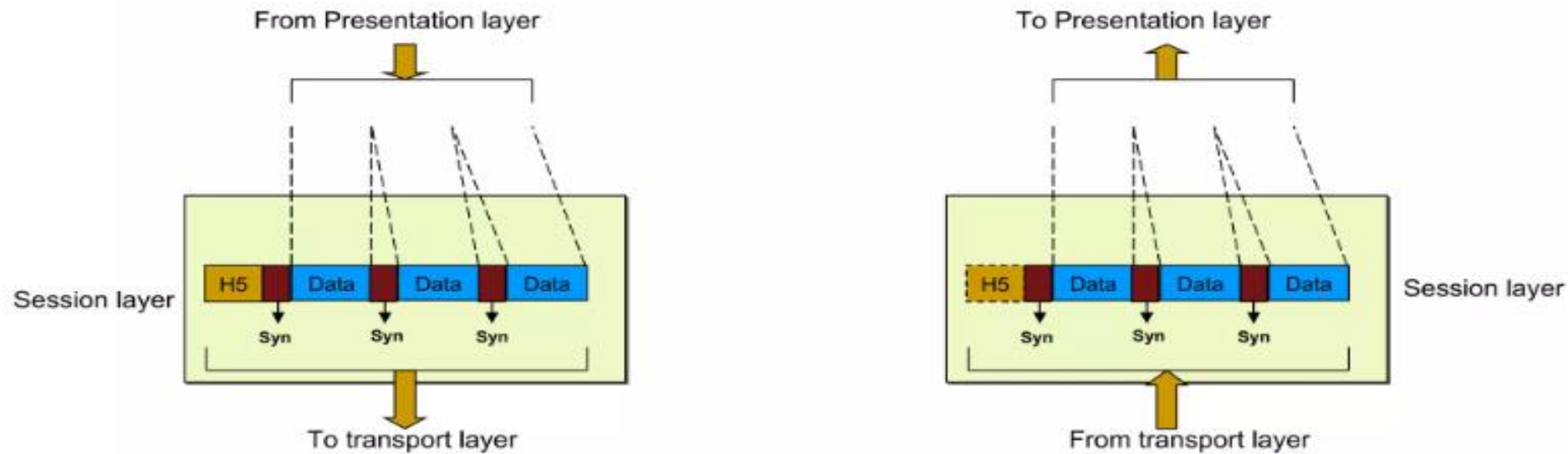

- The session layer is responsible for dialog control and synchronization
- Concerned:
 - Dialog Control (Half Duplex/Full duplex)
 - Synchronization (Synchronization points, process inline within same page)

Presentation Layer (dependency)

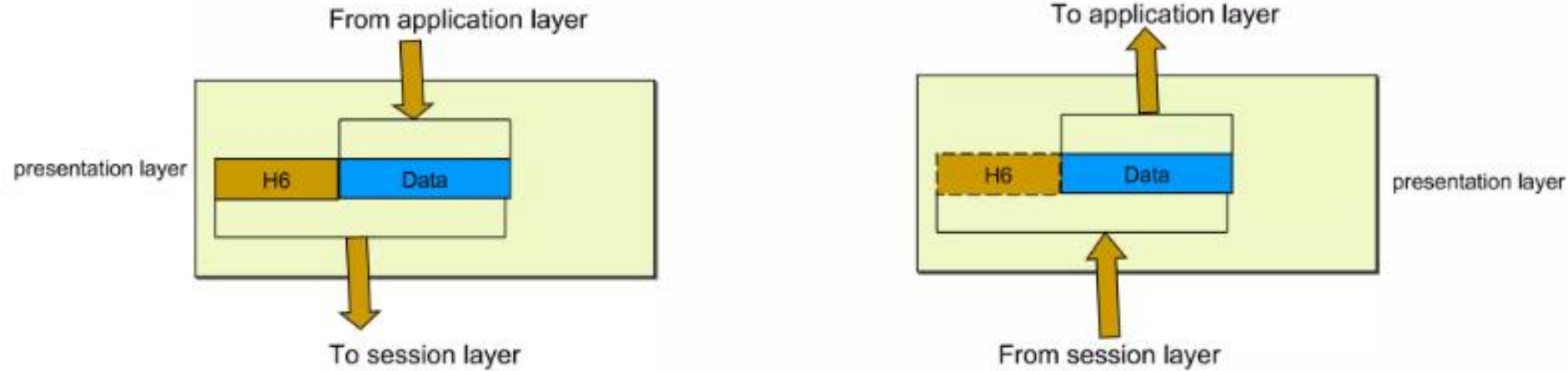

- The presentation layer is responsible for translation, compression and encryption
- Concerned:
 - Translation (interoperability between different encoding system)
 - Encryption (Privacy schemes)
 - Compression (data compression)

Application Layer (user level service)

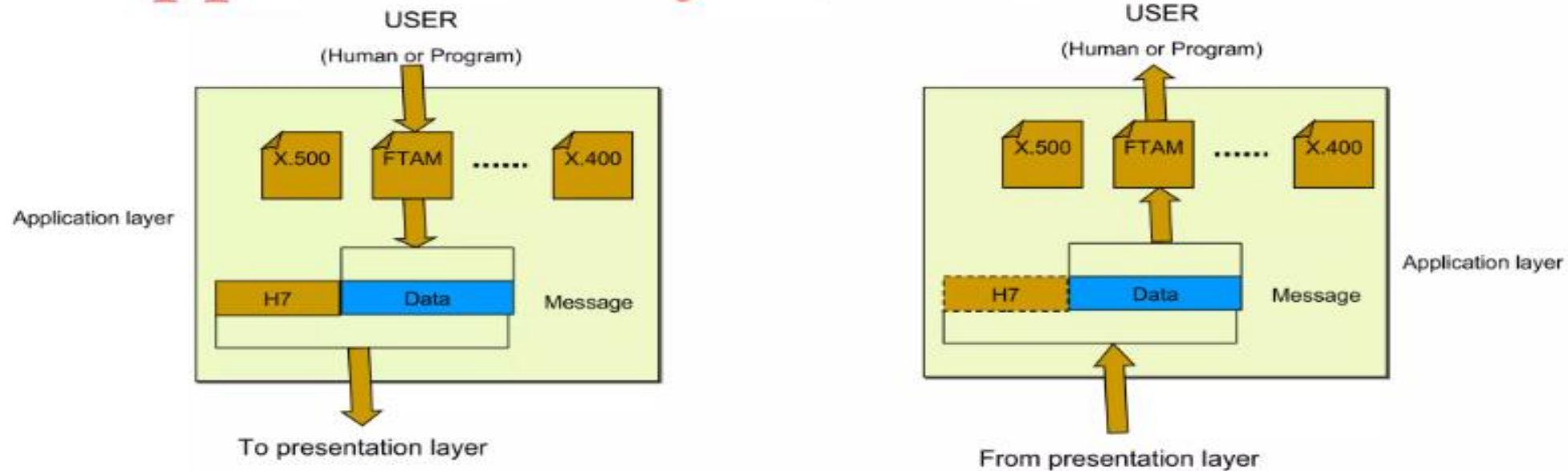

- The application layer is responsible for providing services to the user.
- Concerned:
 - Network virtual terminal (Software)
 - File transfer, access and management
 - Mail services
 - Directory services (access to distributed database sources for global information about various objects and services)